

CLARKE®



WARNING: Read these instructions before using the machine
The welder is supplied set up for no gas welding

NO GAS/GAS MIG WELDER

MODEL NO: MIG 106

PART NO: 6014011

OPERATION & MAINTENANCE INSTRUCTIONS



LS1018 - ISS 1

INTRODUCTION

Thank you for purchasing this CLARKE MIG Welder.

Before attempting to operate the machine, it is essential that you read this manual thoroughly and carefully follow all instructions given. In doing so you will ensure the safety of yourself and that of others around you, and you can also look forward to the welder giving you long and satisfactory service.

GUARANTEE

This CLARKE product is guaranteed against faulty manufacture for a period of 12 months from the date of purchase. Please keep your receipt as proof of purchase.

This guarantee is invalid if the product is found to have been abused or tampered with in any way, or not used for the purpose for which it was intended.

Faulty goods should be returned to their place of purchase, no product can be returned to us without prior permission.

This guarantee does not effect your statutory rights.

ENVIRONMENTAL RECYCLING POLICY



Through purchase of this product, the customer is taking on the obligation to deal with the WEEE in accordance with the WEEE regulations in relation to the treatment, recycling & recovery and environmentally sound disposal of the WEEE.

In effect, this means that this product must not be disposed of with general household waste. It must be disposed of according to the laws governing Waste Electrical and Electronic Equipment (WEEE) at a recognised disposal facility.

ACCESSORIES

The following are some of the accessories available from your CLARKE dealer. Please quote the part numbers shown below:

PART	DESCRIPTION	PART NUMBER	COMMENT
Welding Wire Spools	Flux cored mild steel (mini spool) 0.9mm	8132110	Use for no gas welding
	Mild steel (mini) - 0.6mm	8132100	Use for gas welding
	Mild steel (mini) - 0.8mm	8132070	Use for gas welding
	Stainless Steel 0.8mm (mini spool)	8132090	
Welding Gas	CO ₂ (250g)	6000642	For welding mild steel
	CO ₂ (600g)	6000643	For welding mild steel
	CO ₂ /Argon Mix	6000660	For welding stainless/ thin sheet mild steel
Welding Tips	0.6 mm (pack of 5)	8132260	
	0.8 mm (pack of 5)	8132270	
	1.0 mm (pack of 5)	8132275	

A Gas regulator, Arc Activated Headshields, Anti-spatter Spray, Swan Necks, Torch Shrouds and Torch Liner are also available from your CLARKE dealer or our parts division.

CONTENTS

INTRODUCTION	2
GUARANTEE	2
ENVIRONMENTAL RECYCLING POLICY	2
ACCESSORIES	3
CONTENTS	4
GENERAL SAFETY INSTRUCTIONS	5
ELECTRICAL CONNECTIONS	8
SAFETY SYMBOLS	9
UNPACKING	9
Opening The Side Panel	10
Fitting the Gas bottle Holder	10
THE WELDING SHIELD	11
OVERVIEW	12
The Control panel	13
PREPARATION FOR USE	14
Mounting The Welding Wire Spool	14
Setting The Drive Roller Size	14
Threading The Wire	15
MIG WELDING PRINCIPLES	17
GAS/NO-GAS SELECTION	17
Welding Without Gas	18
Welding With Gas	18
OPERATING THE WELDER	18
Preparing The Workpiece	18
Operation	19
Thermal Overload	20
Duty Cycle	20
MAINTENANCE	21
RATING PLATE	22
SPECIFICATIONS	23
ARC ACTIVATED HEADSHIELDS	24
TROUBLESHOOTING	25
DECLARATION OF CONFORMITY	27

GENERAL SAFETY INSTRUCTIONS



WARNING: WHEN USING ELECTRICAL TOOLS, BASIC SAFETY PRECAUTIONS SHOULD ALWAYS BE FOLLOWED TO REDUCE THE RISK OF FIRE, ELECTRIC SHOCK AND PERSONAL INJURY

WARNING: READ ALL THESE INSTRUCTIONS BEFORE ATTEMPTING TO OPERATE THIS PRODUCT AND KEEP THESE INSTRUCTIONS IN A SAFE PLACE.

ELECTRIC SHOCK

- Remove the plug from the socket and wait 5 minutes to allow the capacitors to discharge before carrying out any servicing or maintenance on this welder.
- Do not touch live electrical parts.
- Never use electrode holders or cables which are damaged.
- Keep working environment, equipment, cables and clothing free from grease, oil, moisture and dirt.
- Ensure welding machine has been correctly earthed.
- The operator must be insulated from the floor and work bench using a dry insulation mat.
- Always ensure a second person is present in case of accident.
- Never change electrodes with bare hands or damp gloves.
- Keep welding cables away from power cables.
- Regularly inspect the condition of the cables for signs of damage.
- Remove the plug from the mains socket when not in use, do not leave the machine unattended.
- Make sure that the earth clamp is secured to bare metal adjacent to

the weld seam and when not in use is insulated for safety.

- Keep all equipment well maintained.
- The operator shall prevent gas cylinders in the vicinity of the work piece from becoming part of the welding circuit.

FUMES & GASES

- The welding process generates hazardous fumes as a by-product. Inhalation of these fumes is hazardous to health.
- Keep your head away from the weld to avoid breathing the fumes.
- If welding in confined spaces ensure adequate ventilation and use a fume extractor.
- By-products of welding can react to create a toxic/explosive environment.

FIRE OR EXPLOSION

Welding can cause fires and explosions. Precautions should be taken to prevent these hazards.

- Before starting work ensure the area is clear of flammable materials.
- Move any combustible materials to a safe distance, especially

substances likely to generate a dangerous vapour.

- The welding arc can cause serious burns. Avoid contact with skin.
- Sparks and molten metal are ejected during welding. Take precautions to prevent fire.
- Sparks and molten metal can pass through gaps. Be aware that fire can start out of sight.
- Do not weld pressurised containers, or containers containing flammable vapours e.g. fuel tanks.
- Always have appropriate fire fighting equipment to hand suitable for use in electrical environments.
- Avoid carrying any fuels with you e.g. cigarette lighters or matches.

PERSONAL PROTECTION

- The body should be protected by suitable clothing.
- The use of neck protection may be necessary against reflected radiation.
- Arc machines generate a magnetic field which is detrimental to pacemakers. Consult your doctor before going near active welding equipment/operations.
- The UV and IR radiation generated by welding is highly damaging to the eye, causing burns. This can also affect the skin.
- Always use suitable welding shields equipped with appropriate protection filters.
- Where there are pedestrians and traffic ensure a protective screen is used to avoid accidental arc glare.

- Do not weld in the vicinity of children or animals and ensure no one is looking before striking an arc.
- Wear hearing protection if required.
- Allow the weld time to cool. Hot metal should never be handled without gloves.
- Take care when adjusting or maintaining the torch, that it has had time to cool sufficiently and the welder is disconnected from the mains supply.
- First aid facilities and a qualified first aid person should be available unless medical facilities are close by, for immediate treatment of flash burns of the eyes and skin burns.
- A hard hat should be worn when others are working overhead.
- Flammable hair sprays/gels should not be used by persons intending to weld or cut.

PROTECTIVE CLOTHING

- Wear gauntlet gloves designed for use in welding.
- Wear an apron, and protective shoes.
- Wear cuffless trousers to avoid entry of sparks and slag.
- Avoid oily greasy clothing.
- Protective head and shoulder coverings should be worn when overhead welding.
- Wear helmet with safety goggles or glasses with side shields underneath, appropriate filter lenses or plates (protected by clear glass). This is a MUST for welding

(and chipping) to protect the eyes from radiant energy and spatter. Replace cover glass when broken, pitted or spattered.

NOTE: ALL protective wear inc. masks & head shields MUST comply with PPE Directive 89/686/EEC

GAS CYLINDERS:

- Gas cylinders should be located or secured so that they cannot be knocked over.
- Shield gas containers can explode if damaged. Take care when handling.
- Ensure gas cylinders are shut-off when not in use and between operations.
- Take care that a build-up of gas is not permitted to form in confined areas.
- Cylinders must be in an upright position at all times during use and storage.
- The gas cylinder must never come in to contact with the electrode.
- Follow the manufacturer's instructions for handling, storing and using the gas bottle correctly and safely.
- Use the correct equipment to connect the gas bottle to the welding torch.

ADDITIONAL SAFETY PRECAUTIONS FOR MIG WELDING

- ALWAYS ensure that there is ample free air circulating around the outer casing of the machine, and that the louvres are unobstructed.
- ALWAYS inspect the hose before use to ensure it is in good condition.

- ALWAYS keep the free length of torch hose outside the work area.
- ALWAYS remove all flammable materials from the welding area.
- ALWAYS keep a fire extinguisher handy; -Dry Powder, CO2 or BCF, NOT Water.
- NEVER remove any of the panels unless the machine is disconnected from the power supply, AND never use the machine with any of the panels removed.
- NEVER attempt any electrical or mechanical repair unless you are a qualified technician. If you have a problem with the machine contact your local CLARKE dealer.
- NEVER use or store in a wet/damp environment.
- NEVER continue to weld, if, at any time, you feel even the smallest electric shock. Stop welding IMMEDIATELY, and DO NOT attempt to use the machine until the fault is diagnosed and corrected.
- NEVER point the MIG torch at any person or animal.
- Never touch the MIG torch nozzle until the welder is switched OFF and the nozzle has been allowed to cool off.
- NEVER allow the earth cable or hose to become wrapped around the operator or any person in the vicinity.

ELECTRICAL CONNECTIONS



WARNING: READ THESE ELECTRICAL SAFETY INSTRUCTIONS FULLY BEFORE CONNECTING THE PRODUCT TO THE MAINS SUPPLY.

This product is provided with a standard 13 amp, 230 volt (50Hz), BS 1363 plug, for connection to a standard, domestic electrical supply. Should the plug need changing, make sure that a plug of identical specification is used.



**WARNING: THE WIRES IN THE CABLE ARE COLOURED AS FOLLOWS:
BLUE = NEUTRAL BROWN = LIVE YELLOW AND GREEN = EARTH**

If the colours of the wires in the power cable do not correspond with the markings on the terminals of your plug, proceed as follows.

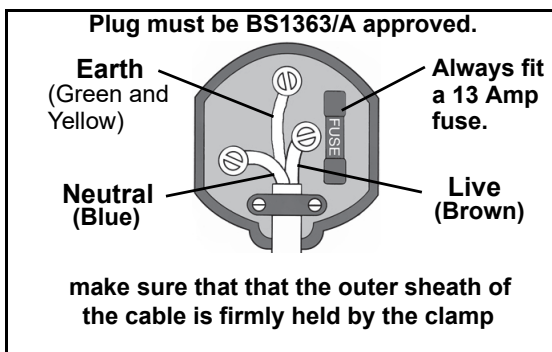

- Connect the **blue** wire to the terminal which is marked **N**.
- Connect the **brown** wire to the terminal which is marked **L**.
- Connect the **Yellow and Green** wire to the terminal which is marked **E** or \perp .



We recommend that this machine is connected to the mains supply via a Residual Current Device (RCD)

If in doubt, consult a qualified electrician. DO NOT attempt any repairs yourself

SAFETY SYMBOLS

	General Warning , indicates that failing to follow these instructions could result in injury or damage to the machine.
	Recycle unwanted materials instead of disposing of them as waste. All tools, accessories and packaging should be sorted, taken to a recycling centre and disposed of in a manner which is compatible with the environment.
	Read Instruction manual before use.

UNPACKING

Any damage or deficiency should be reported to your CLARKE dealer immediately. **Some of the components are stored within the machine side compartment.**

The components include the following:

- 1 x 100 Amp Mig Welder (No Gas / Gas)
- 1 x 0.9 mm tip for no gas welding in the torch
- 1 x 0.9 mm tip
- 1 x 0.8 mm tip
- 1 x 0.6 mm tip
- 1 x 0.9 mm 0.45 kg mini spool flux cored wire (no gas welding)
- 1 x 0.6 mm 0.7 kg mini spool MSW (gas welding)
- 1 x welding shield
- 1 x hammer / brush tool
- 2 x Fixing brackets for gas bottle
- 1 x Instruction Manual

OPENING THE SIDE PANEL



WARNING: NEVER OPERATE THIS MACHINE WITH THE SIDE PANELS PARTIALLY OPENED OR COMPLETELY REMOVED

IMPORTANT: *Ensure that the welder is not connected to the mains supply.*

1. Open the side panel, by pushing the latch down and allowing the side panel to drop down.
2. Remove any loose items that have been transported inside.

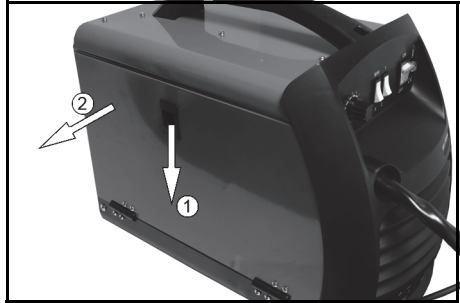

FITTING THE GAS BOTTLE HOLDER

1. Place the lower bottle bracket into position and secure in place using the 2 screws provided.
2. Secure the top clip in place using the screw provided.



THE WELDING SHIELD

1. Push the two halves of the shield together as shown, making sure the hooks and pins on the side engage correctly.
2. Place the handle into position and secure using the plastic nut provided.
3. Insert the clear glass panel into the recess inside the shield, followed by the dark glass panel.
 - The clear glass must be inserted first.
4. Insert the two plastic screws to clamp the glass panels from the inside of the shield.

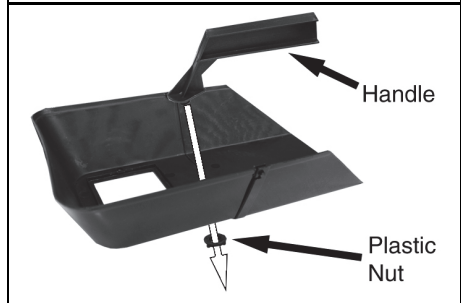
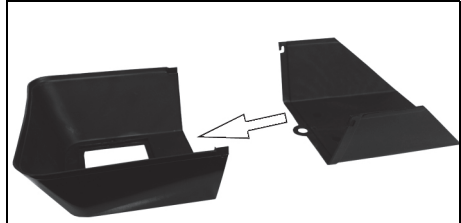

CAUTION: WHEN REPLACING THE GLASS PANELS, ONLY USE PARTS SUPPLIED BY CLARKE INTERNATIONAL. THE DARK PANEL IS A CERTIFIED, SPECIFIC OPTICAL CLASS AND SHOULD NOT BE EXCHANGED FOR ANY OTHER TYPE.

5. Replace the clear glass panel when it becomes badly pitted.

OVERVIEW



NO	DESCRIPTION	NO	DESCRIPTION
1	Carry Handle	5	Torch Hose
2	Gas Connection Point	6	Earth Clamp
3	Control Panel	7	Welding Mask
4	Torch	8	Chipping Hammer

THE CONTROL PANEL

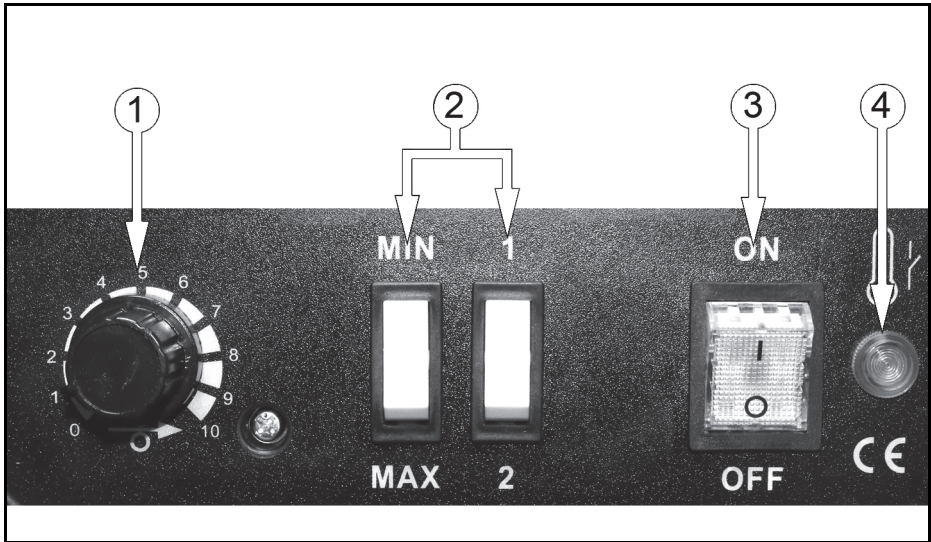

1. Wire speed control knob. As a general rule, a higher current requires a higher wire speed.

2. Current setting switches MIN-MAX & 1-2. Used together these two switches provide 4 increasing power levels as follows:

- MIN-1
- MIN-2
- MAX-1
- MAX-2.

3. Power ON/OFF switch. When the power is ON the green switch will be illuminated. When the welder is no longer required, the Power On/Off switch should be switched to the OFF position and the plug should be disconnected from the mains supply.

4. Thermal overload light. If the duty cycle is exceeded as a result of welding for too long with a high current, the overload light will illuminate and the welder will turn off. When the welder has cooled down (approx. 5 to 10 minutes), the power will be restored and welding can recommence.

PREPARATION FOR USE

MOUNTING THE WELDING WIRE SPOOL



WARNING: MAKE SURE THAT THE WELDER IS NOT CONNECTED TO THE MAINS SUPPLY.

NOTE: Spools of welding wire are available from your Clarke Dealer.

1. Open the side panel by pushing the latch down and allowing the side panel to open.
2. Remove the locking wingnut and retaining disc.
3. Place a spool of welding wire over the spindle.
 - Do not release the tension on the wire as it will unravel causing feeding problems later.
 - The wire will feed off the spool clockwise from the top of the reel.
 - The spool must be fitted with the correct orientation otherwise it will not feed correctly.

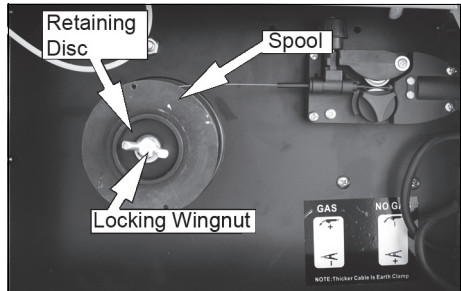

SETTING THE DRIVE ROLLER SIZE

1. Loosen the tensioning knob and pivot it towards you.
2. Lift up the arm.
3. Take hold of the triangular knob on the drive roller cover and rotate it 90° anticlockwise to release it.
4. Pull the roller retainer off the drive spindle to reveal the roller.

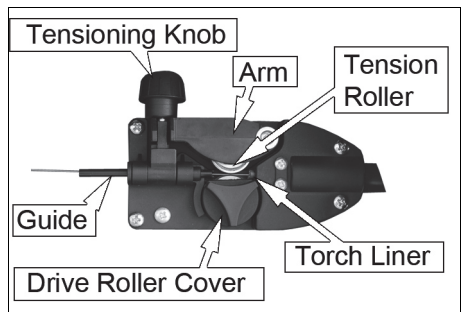

5. Pull the roller off the drive spindle.
 - The groove size is stamped on the corresponding side of the roller. Select the groove size according to the size of the wire you are using and put the roller back on the spindle with your chosen side facing you.

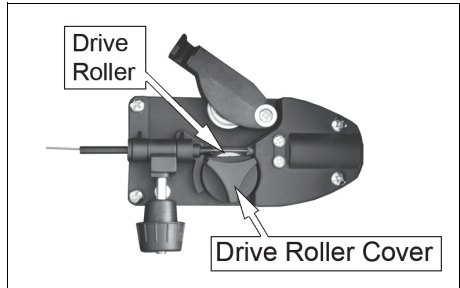

6. Replace the drive roller cover back onto the drive spindle with the opening facing right.
7. Ensure that the flanges at the base of the drive roller cover, seat fully into the circular recess in the main moulding and then rotate the drive roller cover through 90° to lock it in place.

THREADING THE WIRE

IMPORTANT: Do not release the tension on the wire as it will unravel causing feeding problems later.

1. Pull out the end of the wire from the spool, taking care not to release the tension.
 - We recommend you cut off and discard the first 10 cm of wire from the spool to avoid burrs and then straighten the next 15 cm of wire to help with feeding.
2. Loosen the tensioning knob and pivot it towards you.
3. Lift up the arm.
4. Feed the wire through the guide, over the drive roller and into the torch liner.
 - Push about 10-15 cm into the torch liner.
5. Lower the arm and refit the tensioning knob.
 - Tighten the tensioning knob sufficiently to hold in position, but do not fully tighten.

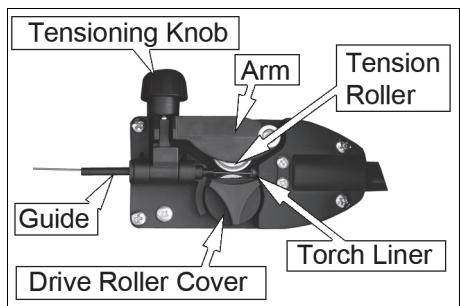

NOTE: Correct tension will allow the wire to feed into the torch liner smoothly, but will allow the drive roller to slip in the event of a blockage.

6. Close the side panel of the welder.
7. Pull off the torch shroud with a twisting movement, then unscrew the contact tip.
8. Connect the welder to the power supply and switch ON.

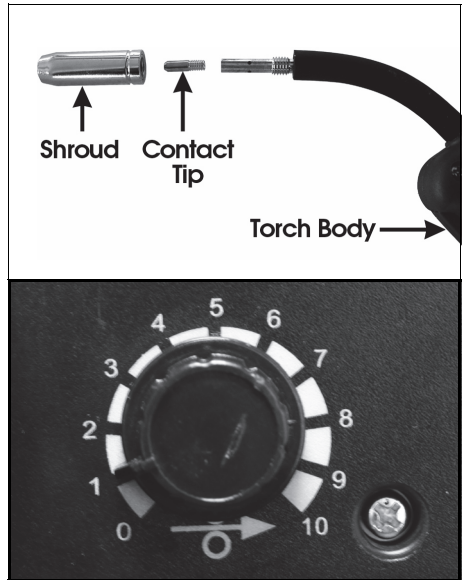

9. Set the 'WIRE FEED' rotary control on the front panel to position 7 or 8 and squeeze the trigger on the torch body.

- The wire will feed through the hose until it appears at the torch tip.
- Ensuring the hose is free from kinks during this process will assist the wire in its passage through the hose liner.

10. Release the trigger and switch off the welder and disconnect the machine from the mains supply.

11. Refit the appropriate size contact tip (0.9 mm, for no gas welding is supplied fitted) to suit your wire. then replace the shroud.

- A spare 0.8 mm tip is supplied loose and should be used when using 0.6/0.8 mm mild steel solid wire.

12. Trim the welding wire so that it protrudes no more than 5 mm from the end of the contact tip.

MIG WELDING PRINCIPLES

MIG (Metal Inert Gas) welding allows you to fuse together two similar metals without altering the properties of the metal.

A consumable wire electrode is continuously fed through the welding torch that is fitted with a concentric gas nozzle. The wire is connected to a high voltage supply which creates an electric arc between the electrode (the wire) and the workpiece. The arc is used to create the required heat to turn the metal into a molten state. The wire is used as both the electrode and as a filler.

The gas is used to prevent oxidation and to shield the arc and the weld from atmospheric contamination. The choice of gas is dependent upon the material being welded

Metal Being Welded	Suitable Gas	Part number
Mild Steel	Carbon Dioxide (CO ₂)	6000643
Stainless Steel	Argon	6000661
Aluminium		
Thin Sheet Metal/Mild Steel	Carbon Dioxide (CO ₂)/Argon Mix	6000660

When using the welder in a gasless configuration the shielding gas is created from the flux within the welding wire.

When using the welder outside, you may need to erect a wind break to make sure the shielding gas is not blown away, thereby leaving a poor quality weld.

GAS/NO-GAS SELECTION

The welder can be configured to weld, with or without a gas supply according to the type of welding wire being used.

- Mild Steel solid core (With Gas),
- Flux Cored (No Gas)

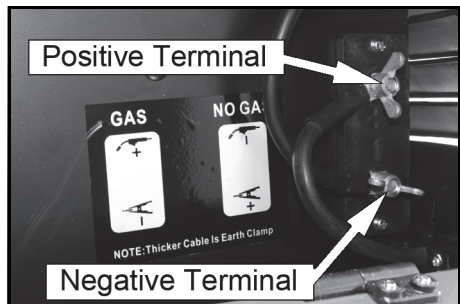

WELDING WITHOUT GAS

1. If using 0.9mm flux cored wire, connect the terminal as shown.
 - The earth cable (Thicker Lead) should be connected to the positive (Red) terminal.
 - The cable from torch (Thinner Lead) should be connected to the Negative (Black) terminal.

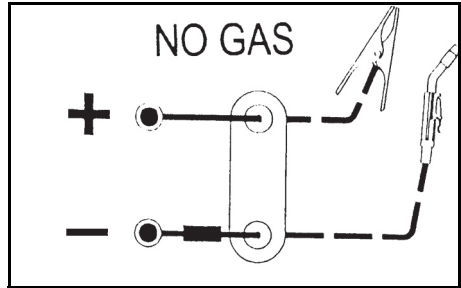

WELDING WITH GAS

1. If using solid cored wire 0.6/0.8mm wire, connect the terminal as shown.
 - The earth cable (Thicker Lead) should be connected to the negative (Black) terminal.
 - The cable from torch (Thinner Lead) should be connected to the positive (Red) terminal.

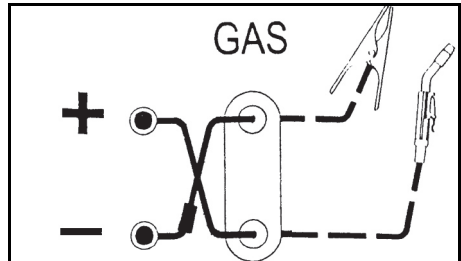

CONNECTING THE GAS SUPPLY

2. Connect a bottled gas supply to the small tube at the back of the welder.

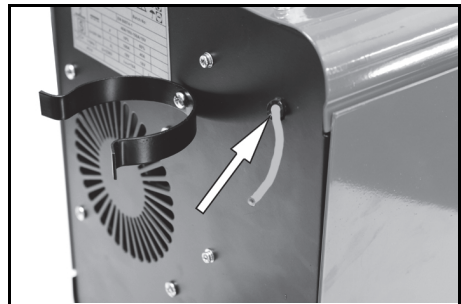

OPERATING THE WELDER

PREPARING THE WORKPIECE

The area being welded should be perfectly clean. Any coating, plating or corrosion must be removed, otherwise a good weld will be impossible to achieve.

Attach the earth clamp to the workpiece as close to the point of weld as possible, without it being intrusive.

OPERATION



CAUTION: THE DUTY CYCLE MUST BE ADHERED IN ORDER TO PREVENT THE THERMAL OVERLOAD PROTECTION FROM ACTIVATING

1. With the welding current set and the wire trimmed, set the wire feed control to 6.
2. Plug the machine into the mains supply and switch on the machine.
3. Cover your face with a welding mask or welding helmet.
 - This is essential.
4. Lower the torch to the workpiece with one hand and approach the work with the torch tip at an angle of about 35° and pull the torch trigger fully.
 - As the wire touches the workpiece, an arc will be struck.
5. In order to produce a satisfactory weld, the controls may be fine tuned as required. This will come with practice.

NOTE: MIG welding is an acquired skill, it is strongly advised that, if you are not fully familiar with this type of welding, you practice on a piece of material with the same characteristics as your workpiece, until you are satisfied with the result, and you have fine tuned your welder to produce a satisfactory weld.

NOTE: One of the problems experienced with novice welders, is the welding wire sticking to the contact tip. This is as a result of the wire feed speed being too slow. It is always better therefore to start with too high a speed, and back off slightly, to avoid the possibility of the wire welding itself to the tip. This is the reason position 6 is recommended for start up.

NOTE: The Wire Feed control is for fine tuning the wire speed. The speed of wire delivery will increase automatically as the current is increased. Therefore, once the ideal speed is achieved by fine tuning, it should not be necessary to adjust this control when the welding current is changed.

NOTE: Listen to the sound made. An irregular crackling sound denotes too high a wire speed. Decrease the speed until a regular, strong buzzing sound is heard.

THERMAL OVERLOAD

The 'Thermal Overload' shuts off the welder when it becomes too hot, due to the duty cycle being exceeded. This is to prevent any damage to the machine.

When this occurs, the warning lamp shown will light up. Allow the welder to cool, until the amber light extinguishes before resuming work.

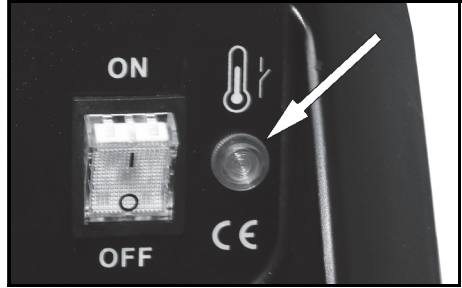

DUTY CYCLE

These welders are covered by regulations EN 60974-1 and EN 50199, where the duty cycle is expressed as a percentage of time the machine may be used in a given period for a specified welding current.

Using the example shown, which is an illustration of the data plate;-

e.g. when welding at 40 amps the machine may be used for 6 minutes (60%) in any 10 minute period.

6014011		Batch No:	
		EN60974 - 1	
40A / 16.0V - 100A / 19V			
VDC	X	10%	60%
	I₂ (A)	100	40
	U₂ (V)	19	16
J₁ = 230V		I₁ max = 18A	I₁ eff = 6.2A

MAINTENANCE



WARNING: ELECTRICITY CAN KILL - NEVER TOUCH LIVE ELECTRICAL COMPONENTS.

WARNING: DISCONNECT THE POWER SUPPLY BEFORE ALL INSPECTIONS AND MAINTENANCE OPERATIONS. BEWARE HOT SURFACES.

WARNING: ALWAYS LET THE WELDER COOL DOWN BEFORE ACCESSING INTERNAL COMPONENTS.

Frequency of maintenance operations depends on the operating conditions, how intensively the welder is used and how clean or dirty the welding site is (aggressive environments etc).

Always inspect the earth cable and torch hose before use, to ensure they are in perfect condition and that the earth clamp is clean and secured correctly to the cable.

Check the hose for security and damage.

As a general rule the power supply should be inspected at least annually. Consult your CLARKE dealer for advice if necessary.

Wire feed unit:

The feed roller wire guide plays an important part in obtaining consistent results. Clean the rollers weekly, especially the feed roller groove, removing all dust deposits.

Torch:

Protect the torch hose assembly from mechanical wear. Clean the liner from the machine forwards by using compressed air. If the liner is blocked it must be replaced.

Contact tip:

The contact tip is a consumable item and must be replaced when the bore becomes enlarged or oval. The contact tip **MUST** be kept free from spatter to ensure an unimpeded flow of gas.

To keep the contact tip free from spatter, we recommend the use of anti-spatter spray (6000715) available from your CLARKE dealer.

Torch shroud:

The torch shroud must also be kept clean and free from spatter. Build-up of spatter inside the gas cup can cause a short circuit at the contact tip which will result in expensive machine repairs.

RATING PLATE

1	Name and address of manufacturer	13	Load Voltage symbol
2	Model number, part number	14	Energy Input symbol
3	Batch number	15	Rated supply voltage
4	Single phase transformer-rectifier	16	Rated maximum supply current
5	British Standards applied	17	Maximum effective supply current
6	Welding process	18	N/A
7	This symbol indicates that the unit is suitable for carrying out welding operations in an environment which has an increased risk of electric shock.	19	N/A
8	Welding Current symbol - direct current.	20	N/A
9	Rated no-load voltage	21	N/A
10	Min+max welding current and corresponding load voltages	22	Degree of protection
11	Duty Cycle symbol	23	Class of protection.
12	Rated Welding Current symbol	24	N/A

SPECIFICATIONS

Model	MIG 106
Part No	6014011
Weight	16.7 kg
Dimensions (l x w x h) mm	460 X 270 X 396
Power Supply	230 V @ 50Hz
IP Rating	IP21S
Output Min/Max Amps	40 /100 Amps
Open Circuit Voltage	16 - 19 V DC
Rated Max Input Current (A)	18A
Welding Capacity (Mild Steel)	4 mm (maximum)

CLARKE International reserve the right to change specifications at any time without prior notice.

DUTY CYCLE

The duty cycle determines the machine 'down time'. i.e 10% means 1 minutes operation followed by 9 minutes of rest. **The duty cycle must be adhered to, to prevent the thermal cutout protection from activating.**

Duty Cycle (%)	10	60
Rated Welding Current (A)	100	40
Conventional Load Voltage (V)	19	16

Do not exceed the stated duty cycle for this machine. Failure to heed this warning may invalidate your warranty.

ARC ACTIVATED HEADSHIELDS

These highly popular headshields activate instantly when the arc is struck and allow you to have both hands free when welding..

Model	Arc Activated	Grinding function	Solar Powered	Fixed Shade	Flip Up	Part Number
GWH4	✓	✓	✓			6000706
GWH7	✓	✓	✓			6000709
GWH5	✓	✓	✓			6000707
GWH6	✓	✓	✓			6000708
GWH3	✓	✓	✓			6000698
GWH2	✓	✓	✓			6000697
PG4	✓	✓	✓			6000716
HS1				✓	✓	6000700
HSF1				✓	✓	6000705

TROUBLESHOOTING

Your CLARKE MIG Welder has been designed to give long and trouble free service. If, however, having followed the instructions in this booklet carefully, you still encounter problems, the following points should help identify and resolve them.

PROBLEM	CAUSE	SOLUTION
No response from welder.	Check fuses and mains lead.	Replace fuses as necessary, if problem persists return welder to your local dealer.
		Check fuse size.
Welder does not feed wire.	Feed motor has malfunctioned.	Return welder to your local dealer.
Feed motor running but no wire being fed from welder tip.	Insufficient Feed Roller pressure.	Increase roller pressure.
	Burr on end of wire.	Re-cut wire square with no burr.
	Liner blocked or damaged.	Clean with compressed air or replace liner.
	Inferior wire.	Use only good "clean" wire.
	Roller worn out.	Replace roller.
Wire welds itself to tip.	Wire feed speed too low.	Unscrew tip, cut wire and fit new tip. Increase wire speed before operating again.
	Wrong size tip.	Fit correct size tip.
Wire feeds into 'birds nest' tangle.	Wire welded to tip.	As above plus reduce feed roller pressure.
	Wire liner damaged preventing smooth operation.	Renew wire liner.
Loose coils of wire tangle around wire drum inside machine.	Locking knob too slack.	Tighten Locking Knob slightly. Do not over-tighten.

PROBLEM	CAUSE	SOLUTION
Erratic wire feed.	Tensioning Knob too tight.	Loosen Tensioning Knob slightly.
	Tension roller worn.	Check and replace if necessary.
	Insufficient pressure on tension roller.	Increase pressure on tension roller Caution: Do not over-tighten .
	Wire dirty, rusty, damp or bent.	Re-cut wire and ensure it is clean.
	Liner partially blocked.	Clean with compressed air.
Poor quality welds.	Insufficient gas at weld area.	Check that gas is not being blown away by draughts and if so move to a more sheltered work area. If not increase gas supply.
	Rusty, painted, damp, oil or greasy workpiece.	Ensure workpiece is clean and dry.
	Rusty/dirty wire.	Ensure wire is clean and dry.
	Poor earth contact.	Check earth clamp/workpiece connection.
Welder cuts out whilst in use.	Duty cycle exceeded (auto cut-out operates).	Allow welder to cool 15-30 mins before continuing. Note: If duty cycle is continually exceeded, damage to the welder may result and welder output is probably too small for application.

If you have any problems which cannot be resolved by reference to the above, or if you require spare parts for your welder please contact your local Clarke dealer.

DECLARATION OF CONFORMITY



Clarke[®]
INTERNATIONAL

Hemnall Street, Epping, Essex CM16 4LG

DECLARATION OF CONFORMITY

This is an important document and should be retained.

We hereby declare that this product(s) complies with the following directive(s):

2014/30/EU Electromagnetic Compatibility Directive.

2014/35/EU Low Voltage Equipment Directive

2011/65/EU Restriction of Hazardous substances.

The following standards have been applied to the product(s):

EN 60974-1:2012, EN 60974-10:2014+A1:2015, IEC 61000-3-11:2000, IEC 61000-3-12:2011.

The technical documentation required to demonstrate that the product(s) meet(s) the requirement(s) of the aforementioned directive(s) has been compiled and is available for inspection by the relevant enforcement authorities.

The CE mark was first applied in: 2018

Product Description: 100 Amp Dual No Gas/Gas MIG Welder
Model number(s): MIG106
Serial / batch Number: n/a
Date of Issue: 14/09/2018

Signed:

J.A. Clarke
Director

A SELECTION FROM THE VAST RANGE OF

Clarke®

QUALITY PRODUCTS

AIR COMPRESSORS

From DIY to industrial, Plus air tools, spray guns and accessories.

GENERATORS

Prime duty or emergency standby for business, home and leisure.

POWER WASHERS

Hot and cold, electric and engine driven - we have what you need

WELDERS

Mig, Arc, Tig and Spot. From DIY to auto/industrial.

METALWORKING

Drills, grinders and saws for DIY and professional use.

WOODWORKING

Saws, sanders, lathes, mortisers and dust extraction.

HYDRAULICS

Cranes, body repair kits, transmission jacks for all types of workshop use.

WATER PUMPS

Submersible, electric and engine driven for DIY, agriculture and industry.

POWERTOOLS

Angle grinders, cordless drill sets, saws and sanders.

STARTERS/CHARGERS

All sizes for car and commercial use.

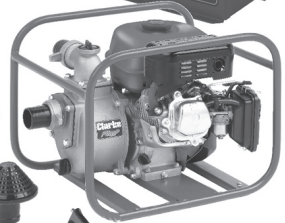
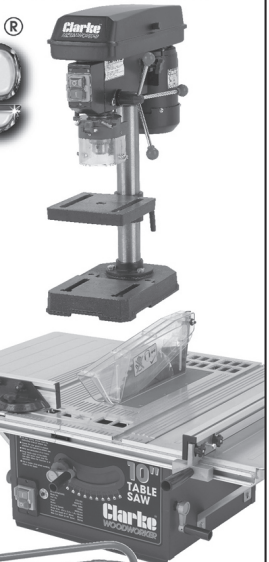

PARTS & SERVICE: 0208 988 7400
E-mail: Parts@clarkeinternational.com or Service@clarkeinternational.com

SALES: UK 01992 565333 or Export 00 44 (0)1992 565335

Clarke® INTERNATIONAL Hemnall Street, Epping, Essex CM16 4LG
www.clarkeinternational.com